

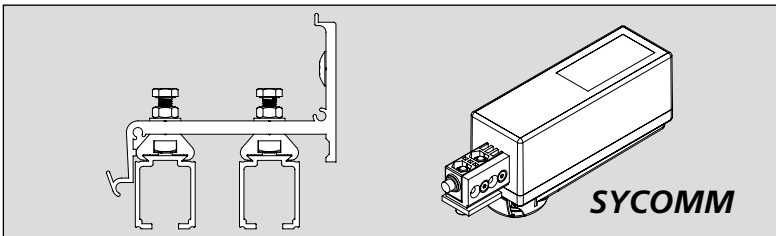

VOLETS COULISSANTS MOTORISÉS : 2 PANNEAUX EN PARALLÈLE
MOTORISERTE SCHIEBEFENSTERLÄDEN : 2 FLÜGEL
MOTORIZED SLIDING SHUTTERS – 2 PANELS
MALLORQUINAS CORREDERAS MOTORIZADAS : 2 HOJAS



SLIDSOFT®

calcule instantanément le détail des composants (quantitatif, dimensionnement ...)

listet sofort die benötigten Artikel auf

list instantaneously the required items

Calcula al momento el despiece completo del sistema

www.mantion.com

Poids maximal des panneaux Maximales Gewicht Maximum weight Peso máximo por hoja	80 Kg
Epaisseur des panneaux Ladendicke Shutter thickness Espesor de las hojas	27 - 40 mm

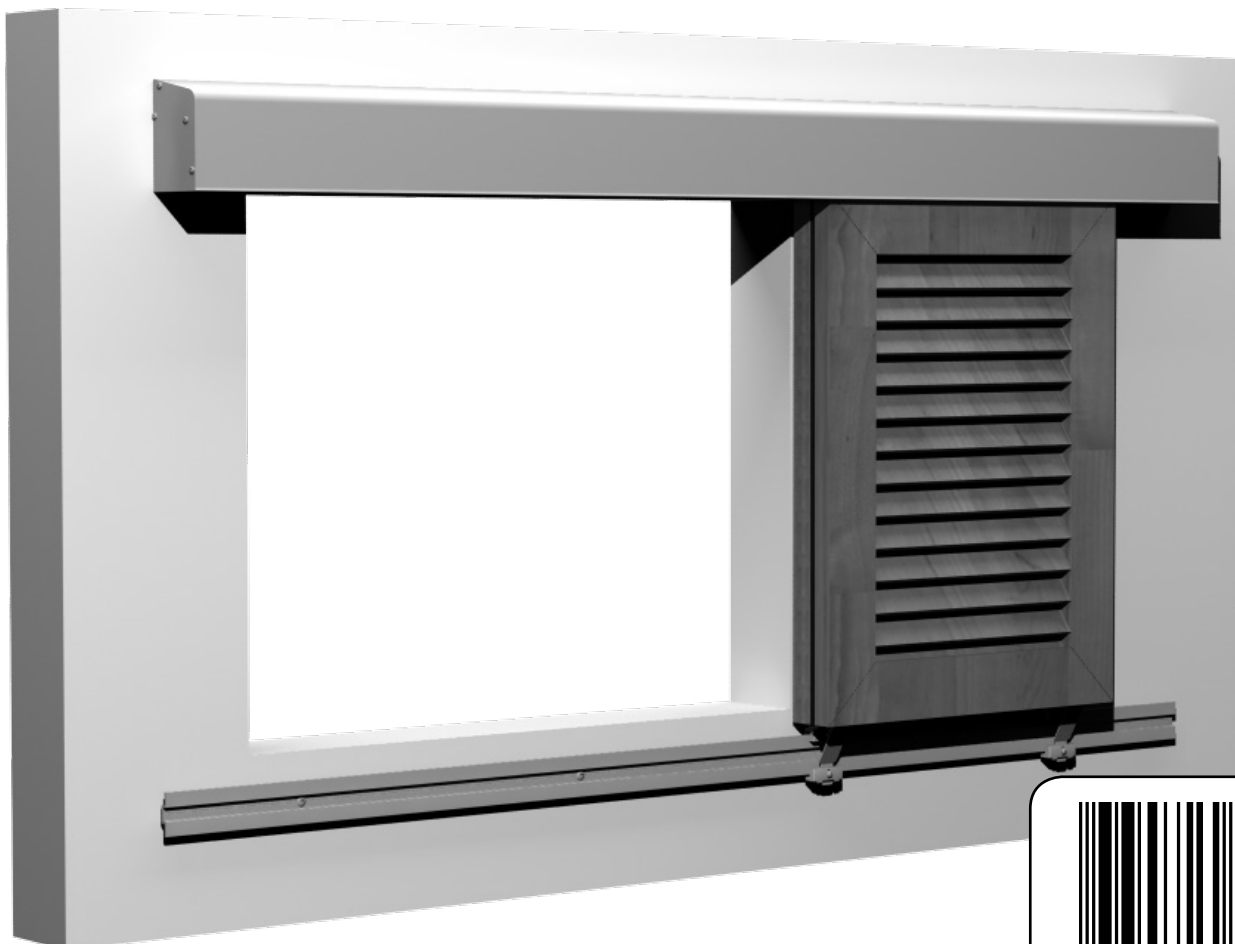

COMPOSITION - ZUSAMMENSETZUNG - COMPOSICIÓN

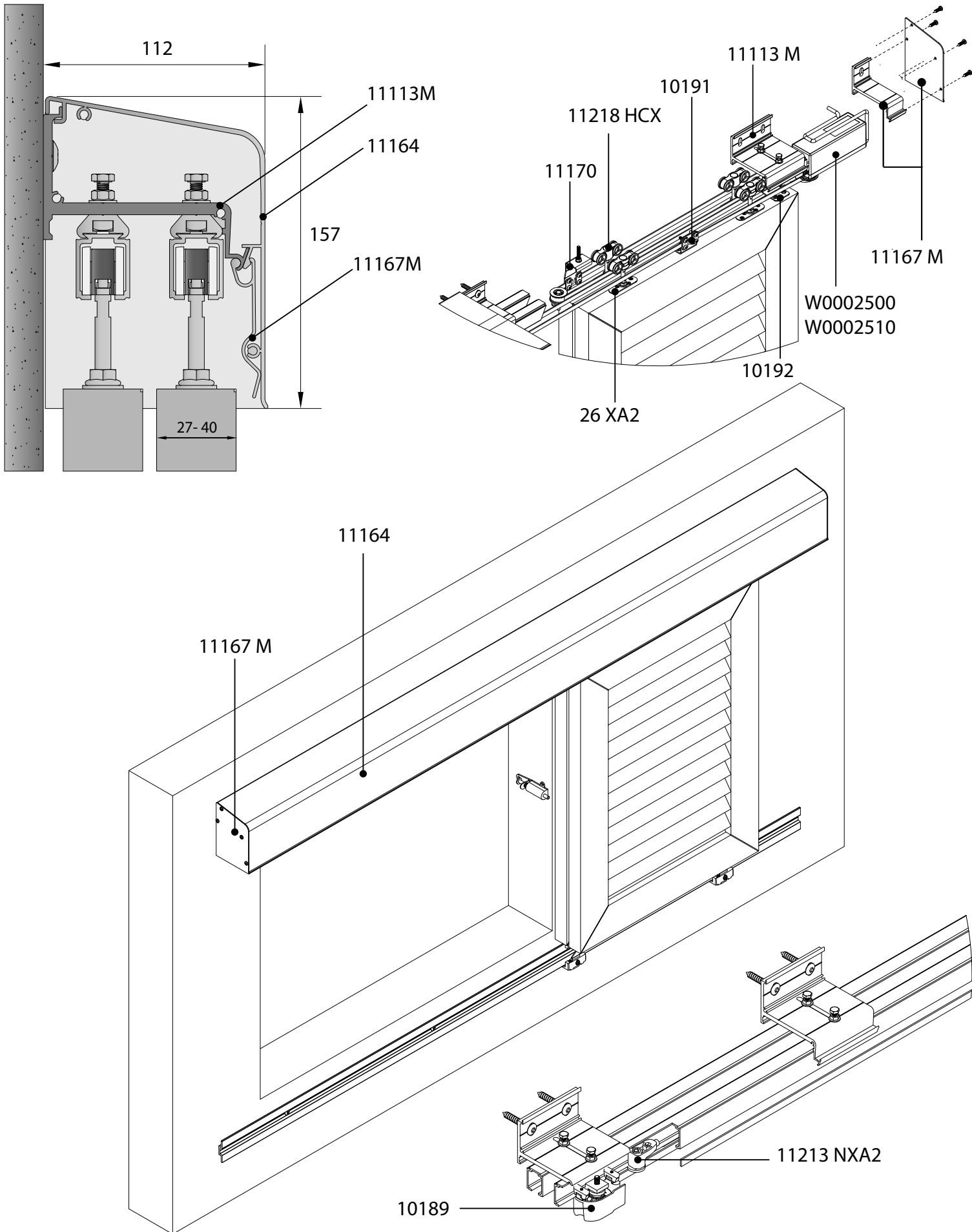

SORTIE DE CABLE - KABELAUSLAUF CABLE OUTLET - SALIDA DEL CABLE

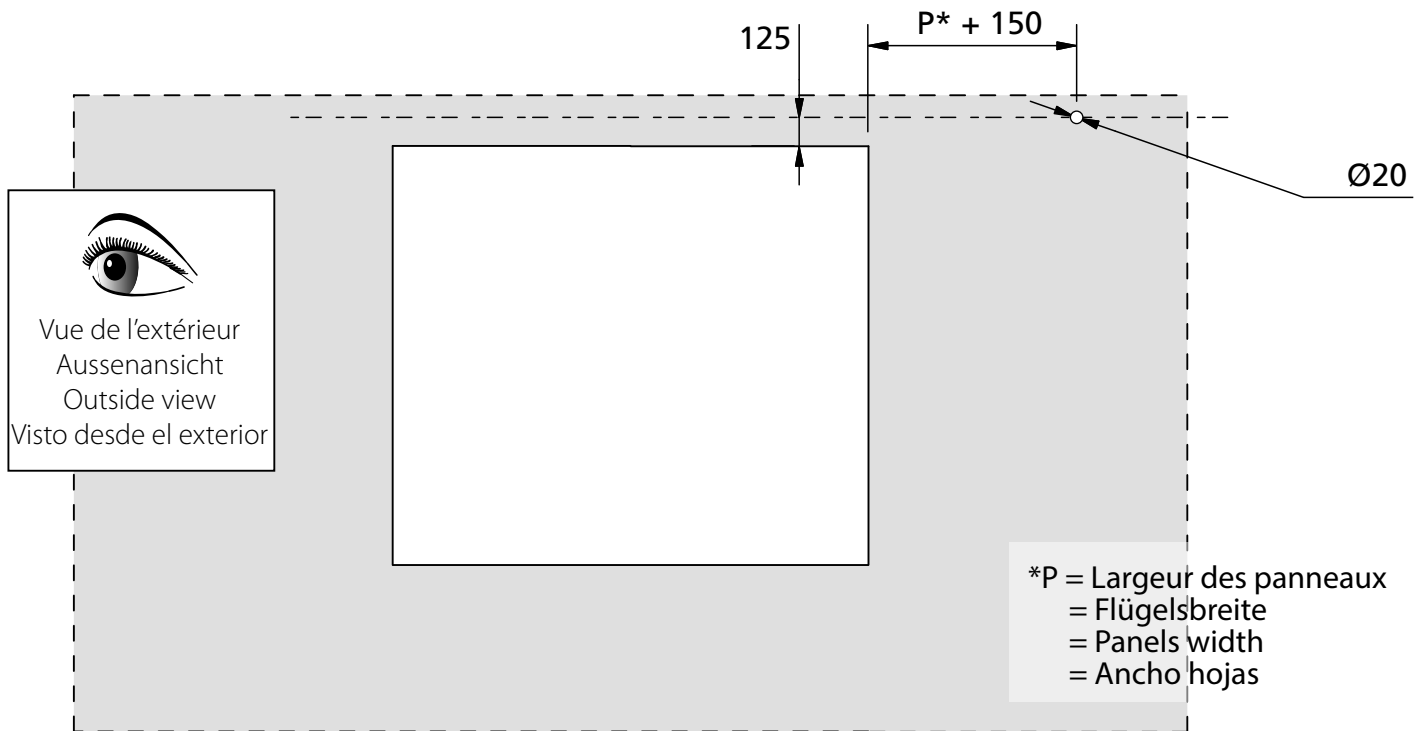

Montage représenté avec ouverture à droite. Pour une ouverture à gauche, faire une symétrie du croquis.
Assembly shown with right opening. For a left opening, make a sketch of symmetry.
Die Abbildung zeigt ein rechtes Öffnen. Für ein linkes Öffnen symmetrische Abbildung.
Montaje presentado con apertura a la derecha. Para un montaje a la izquierda, hacer una simetría del croquis

motorisation en position GAUCHE
drive located on LEFT hand side
Motorposition LINKS
motor situado a la IZQUIERDA

motorisation en position DROITE
drive located on RIGHT hand side
Motorposition RECHTS
motor situado a la DERECHA

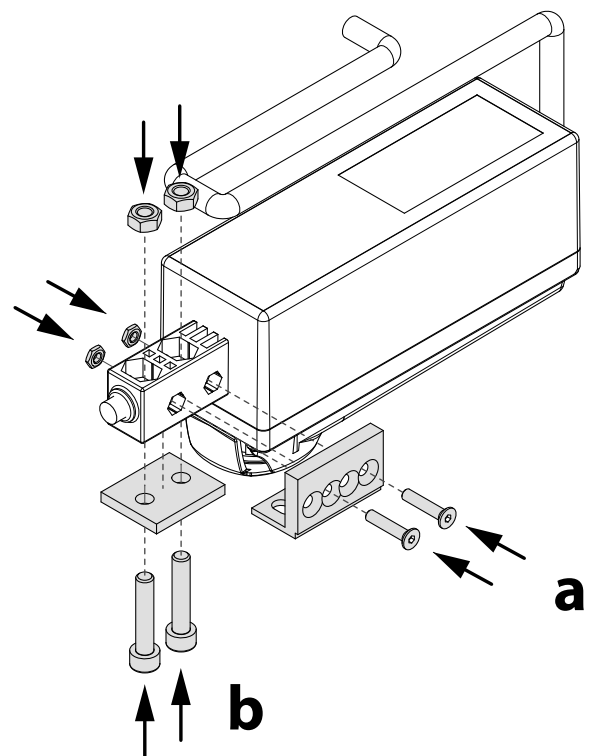
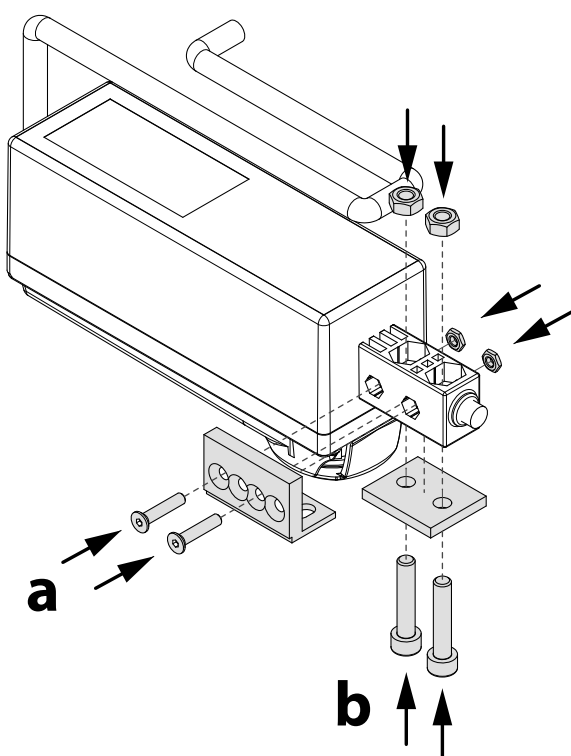

1.

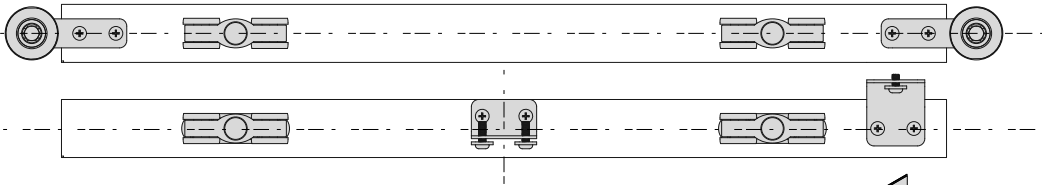
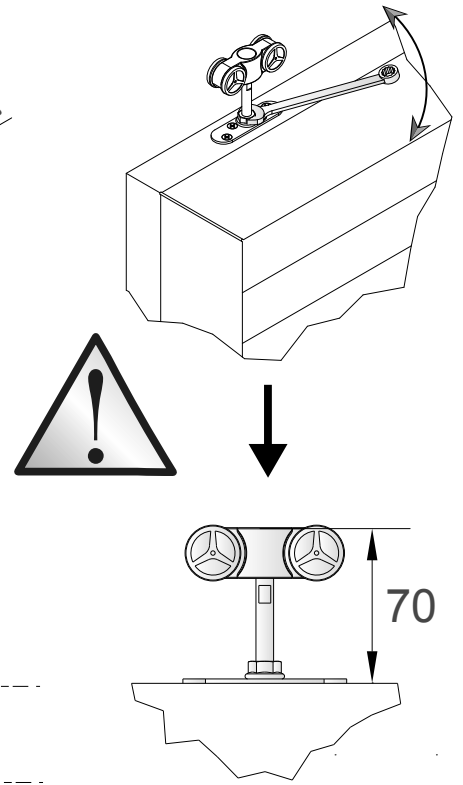
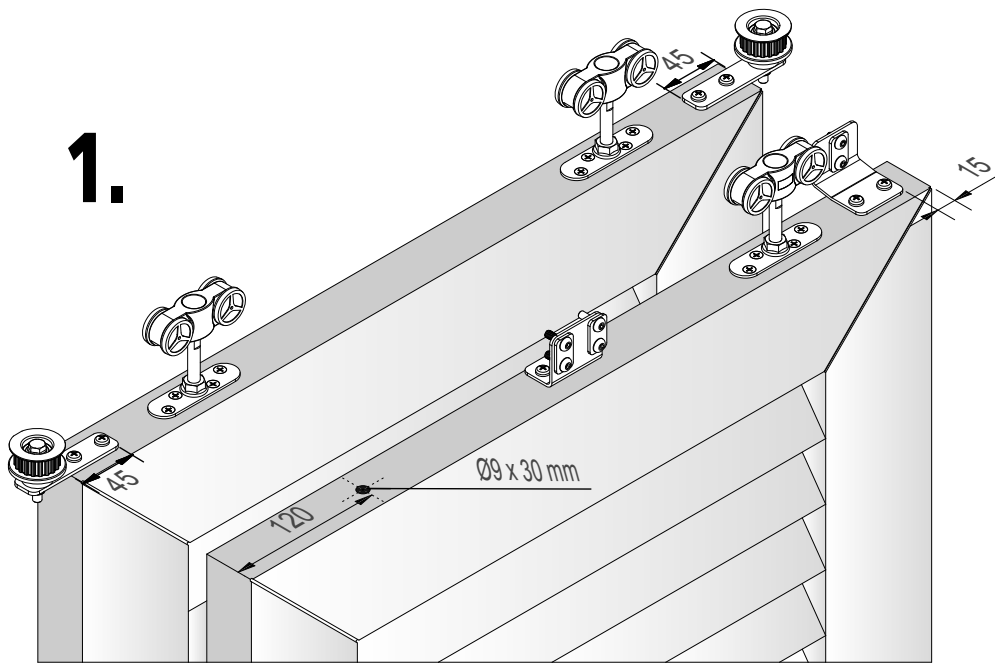

2.

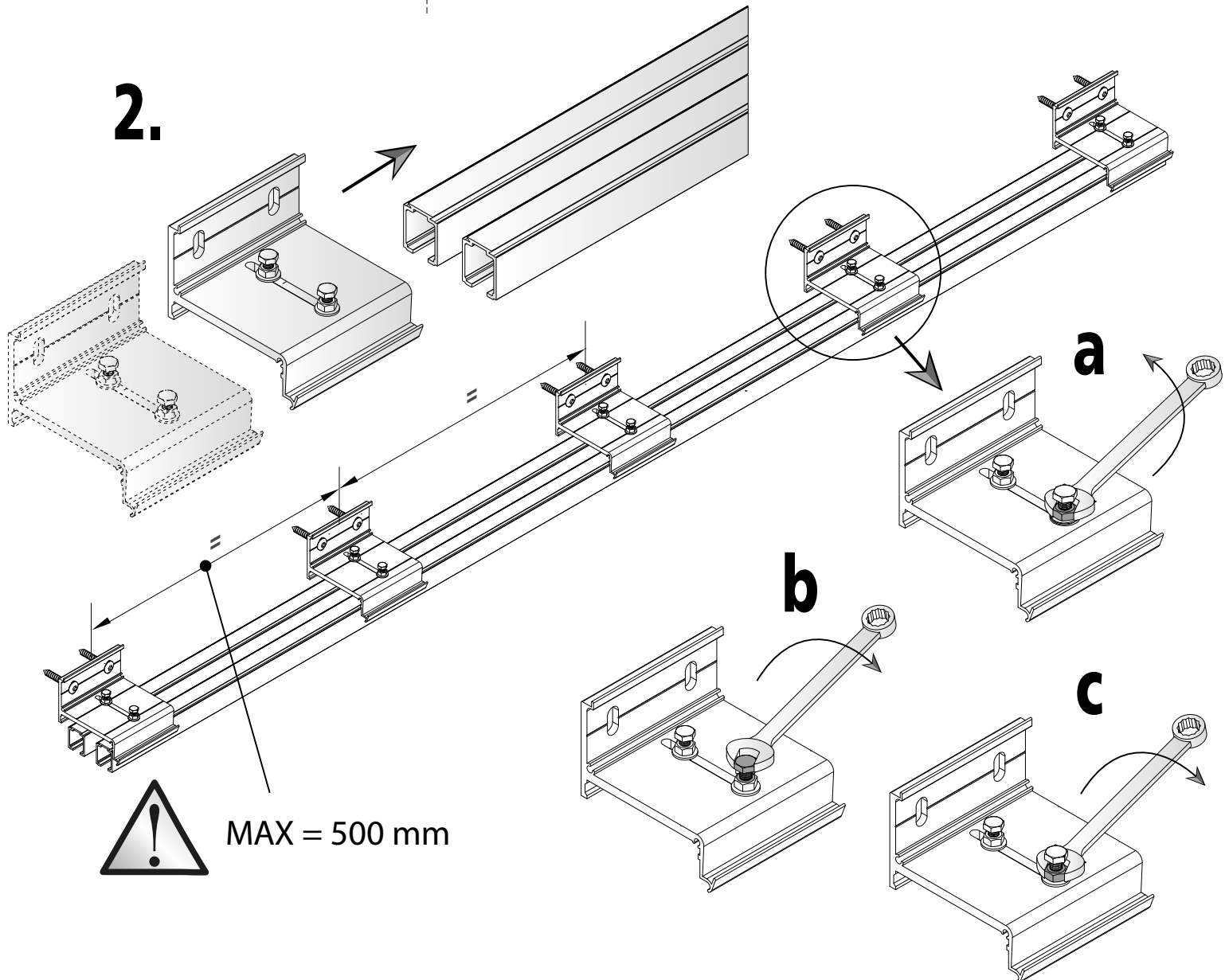

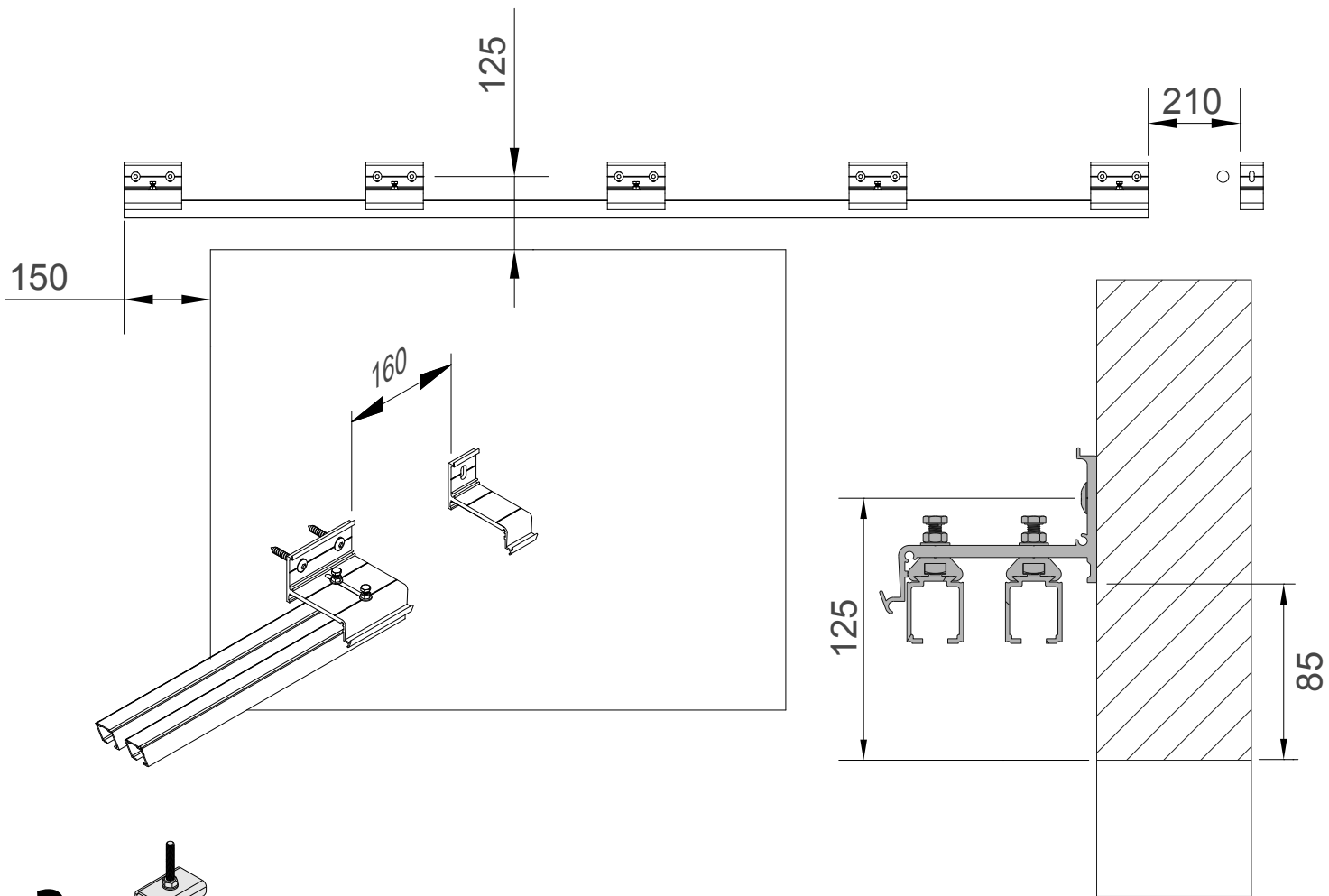

3.

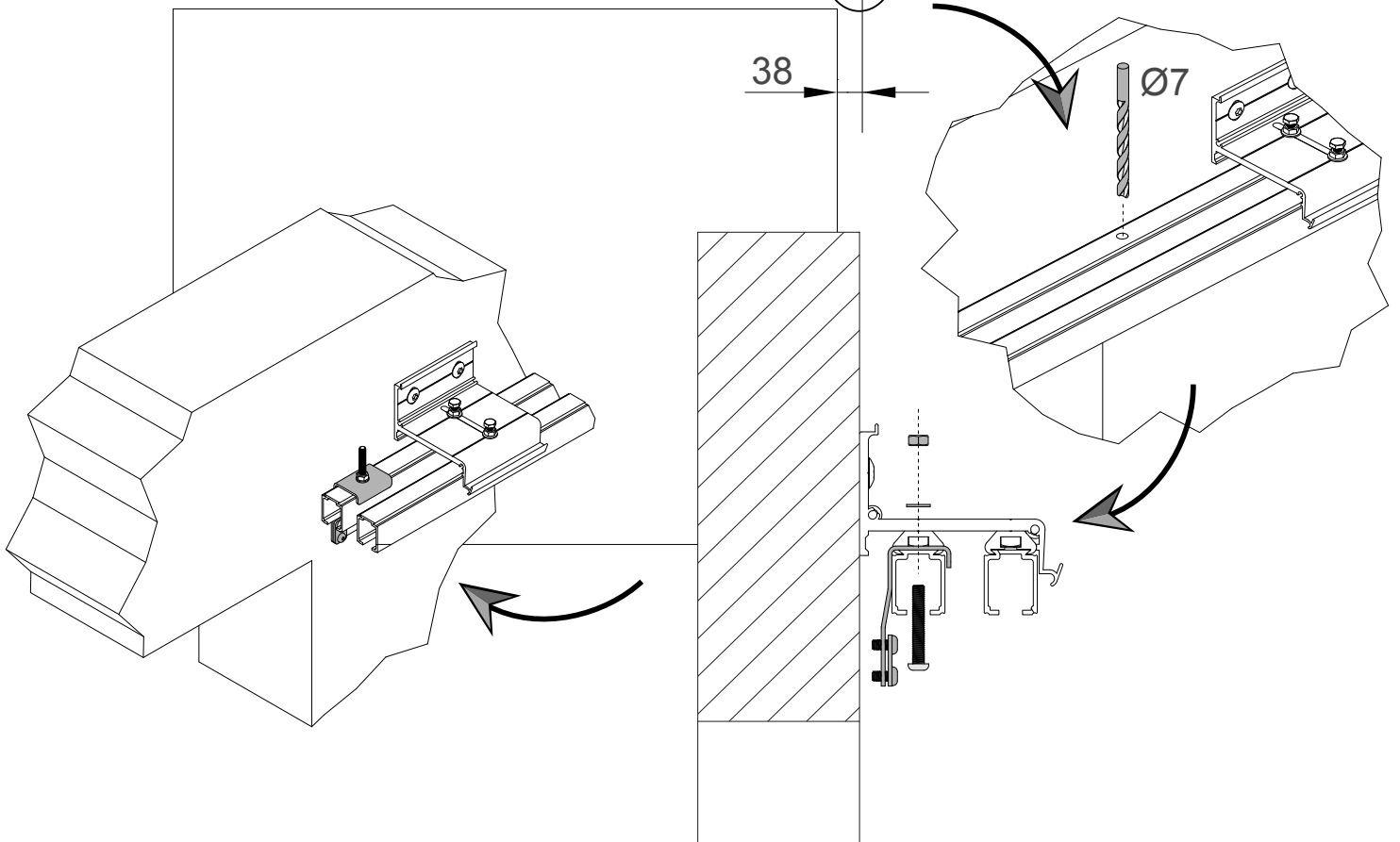
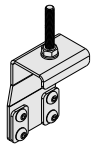

4.

4.2  x2

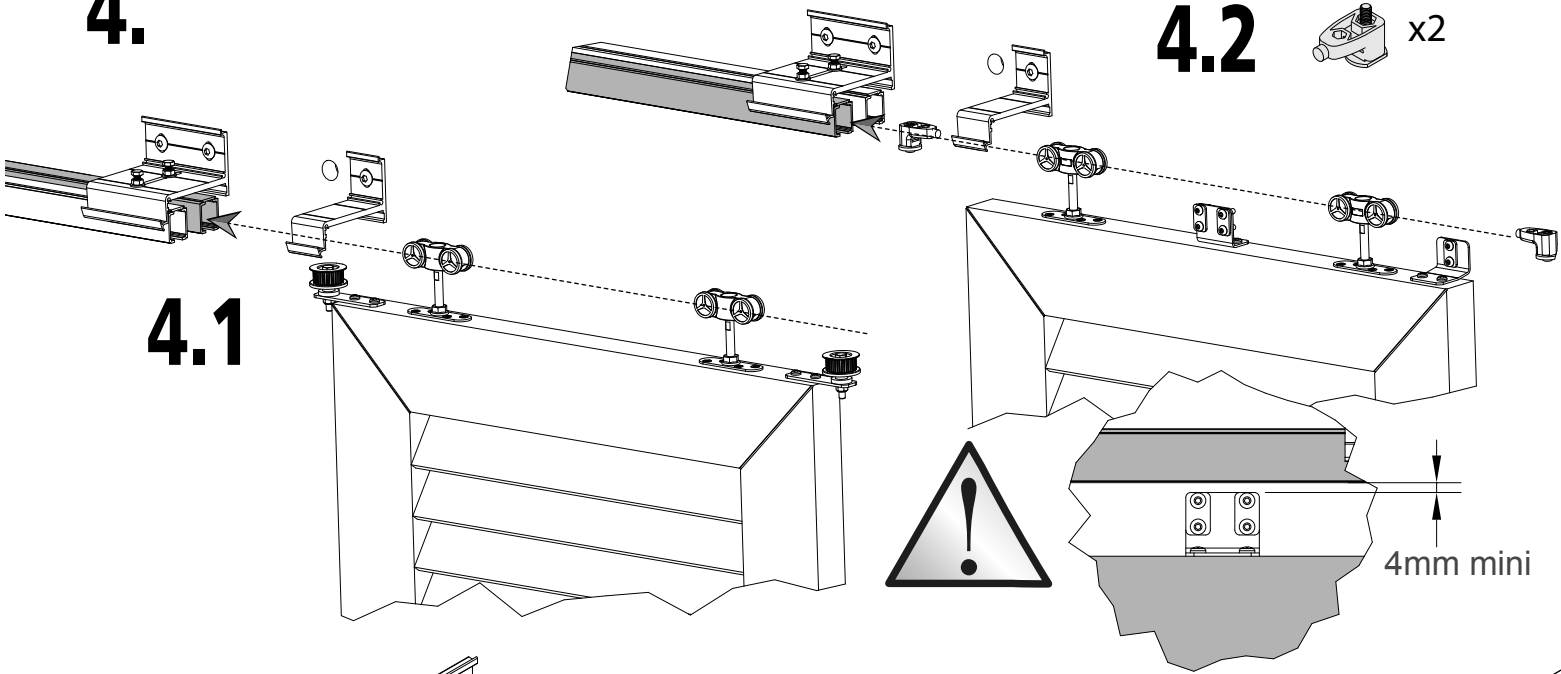

5.

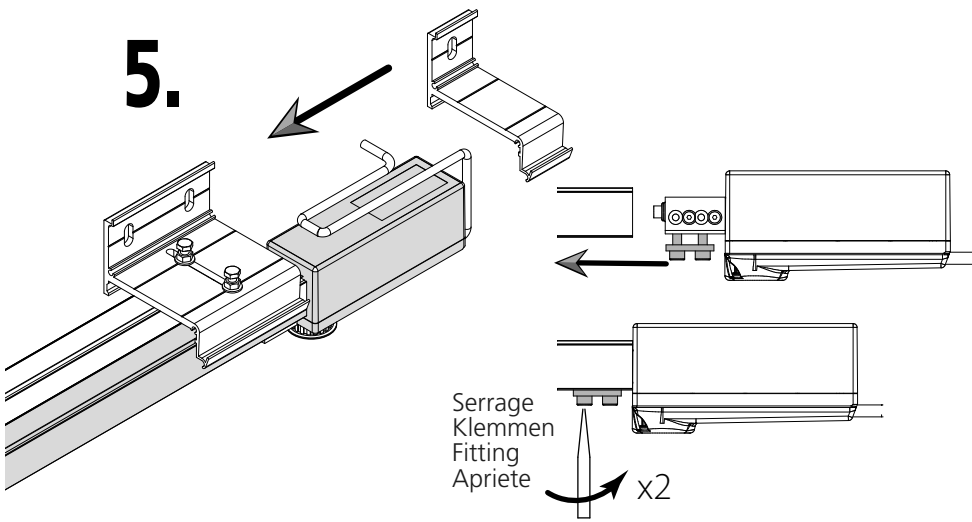

6.

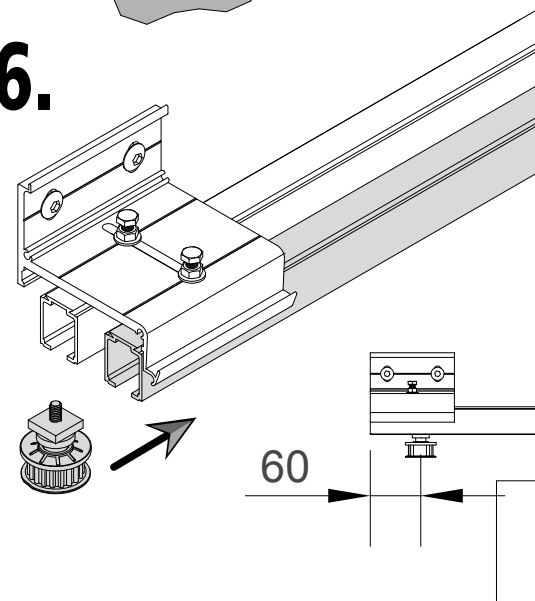

7.

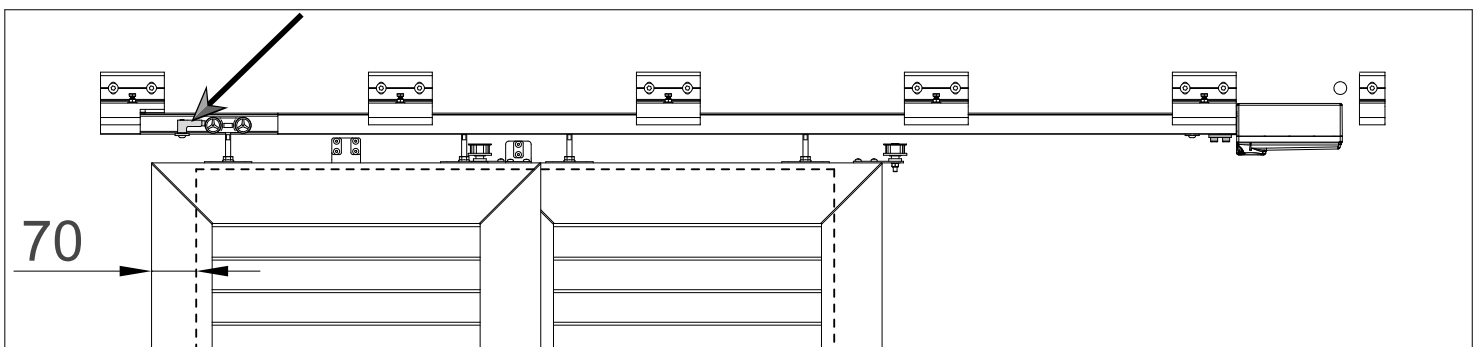
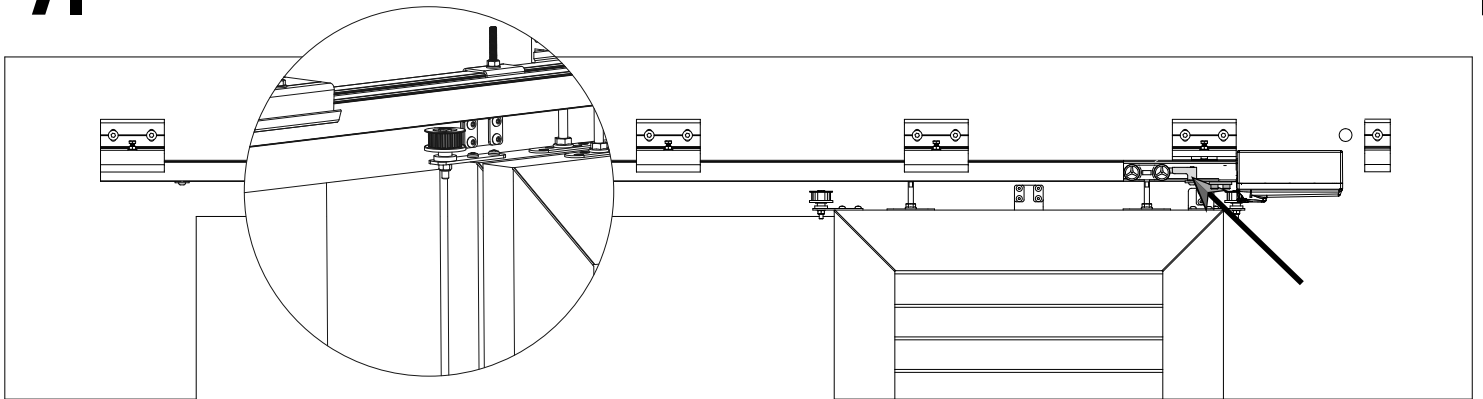

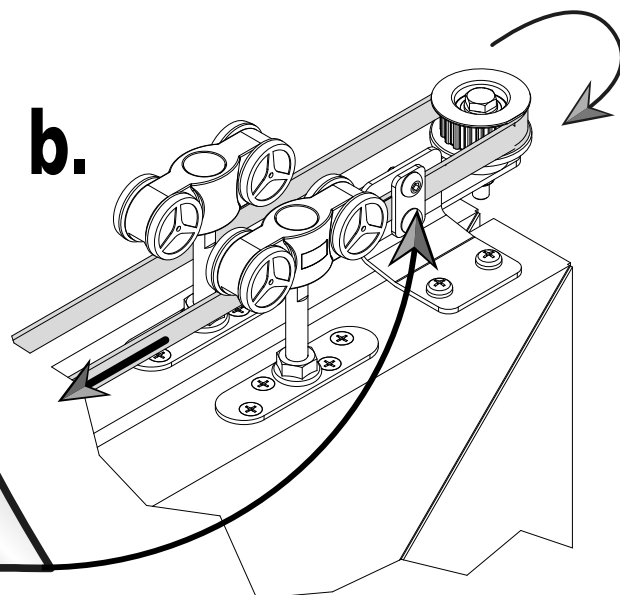
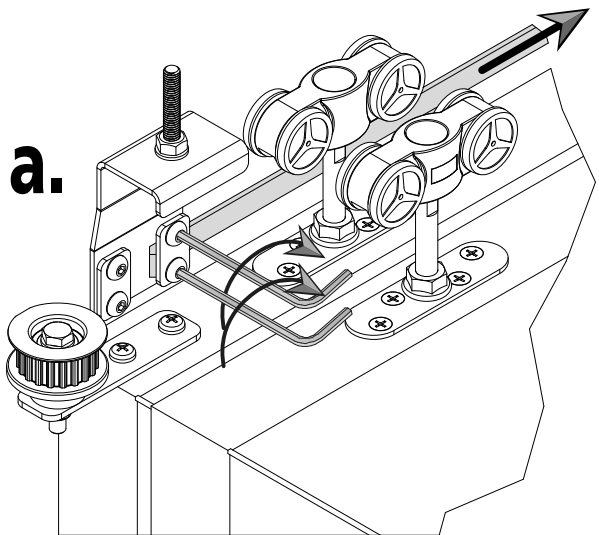

Ne pas serrez
Do not tighten
Nicht anziehen
No apriete

8.

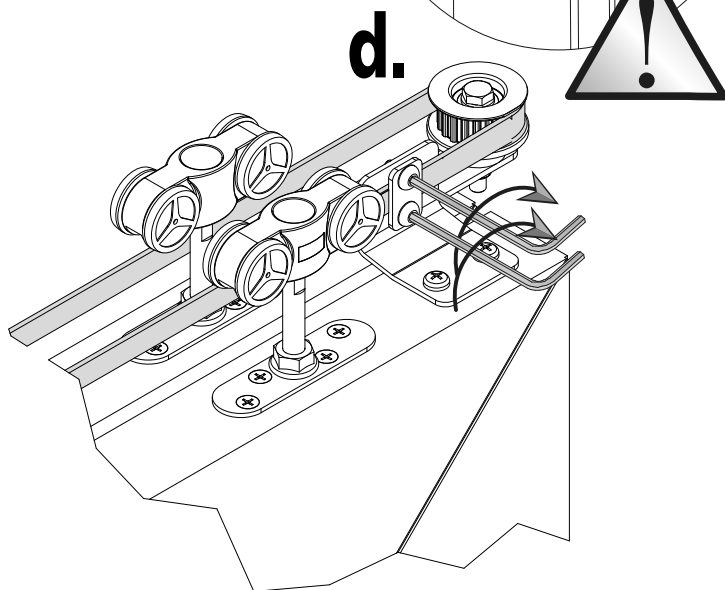
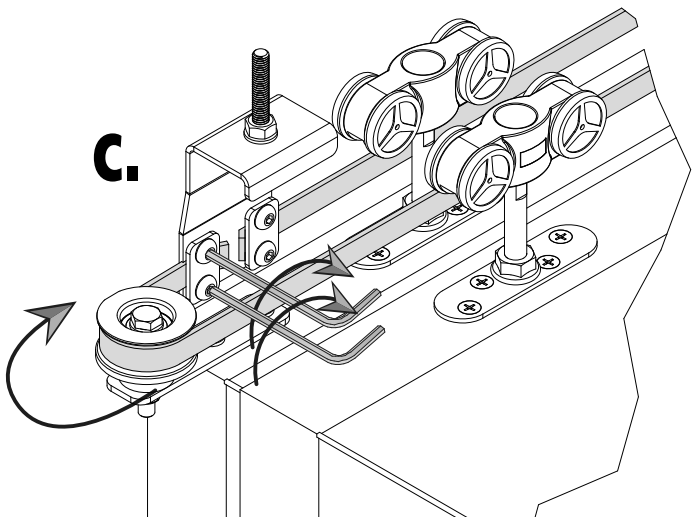
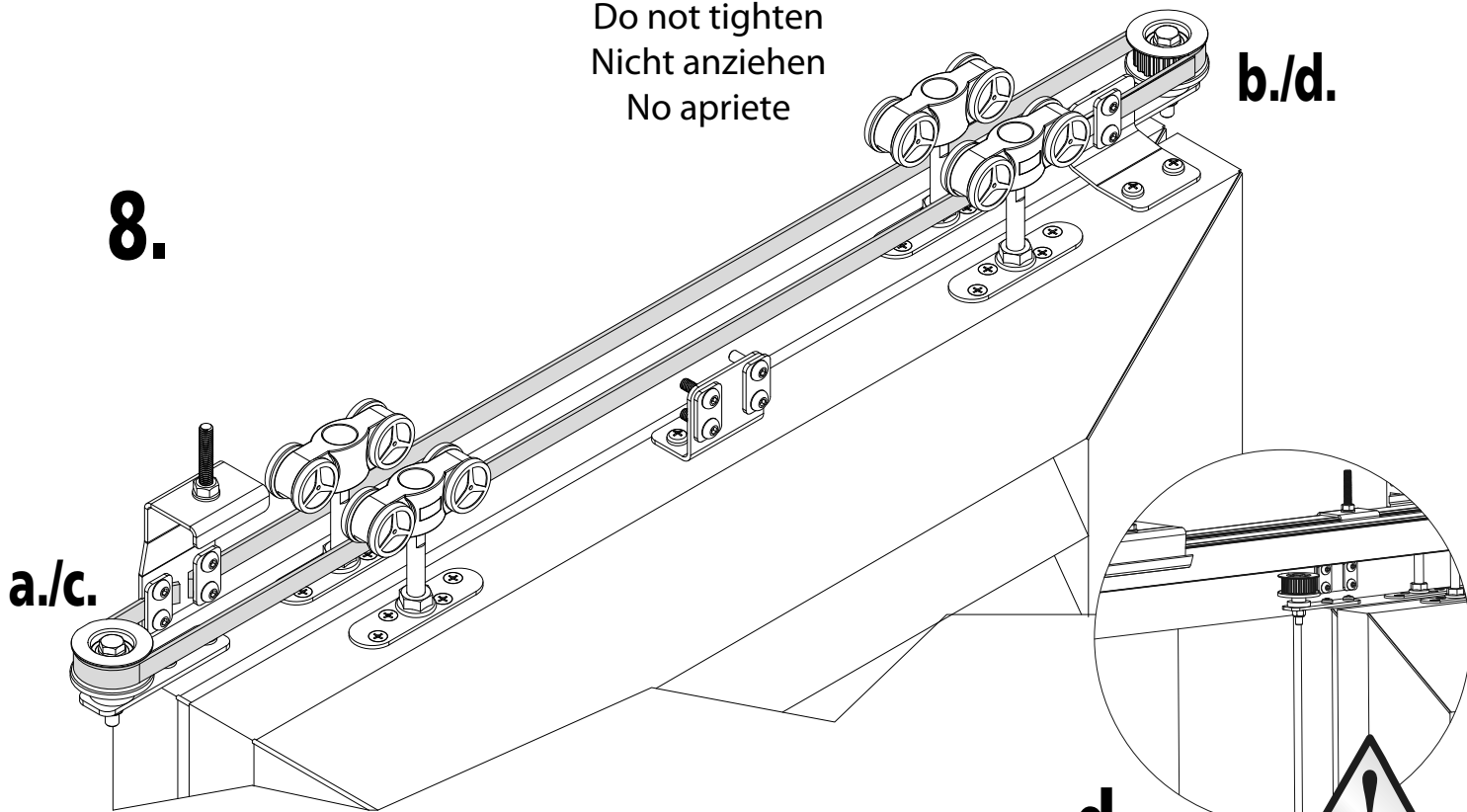

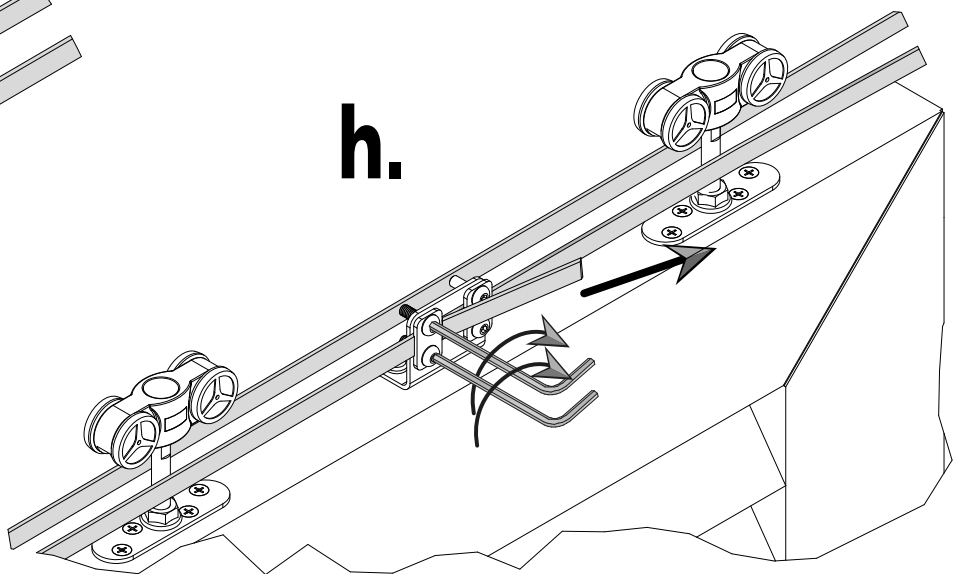
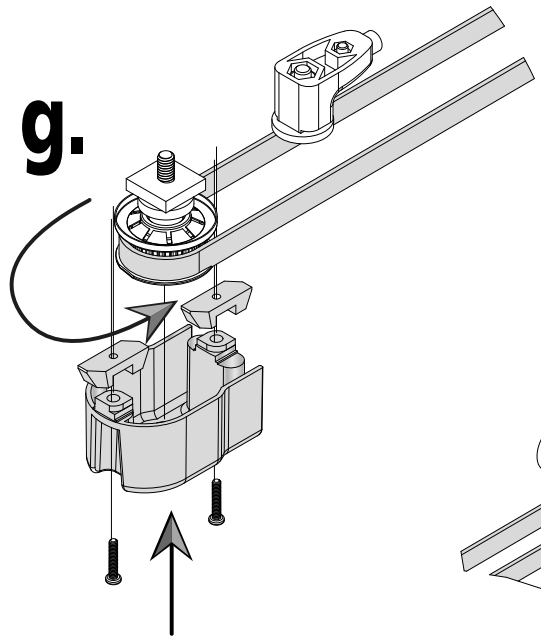
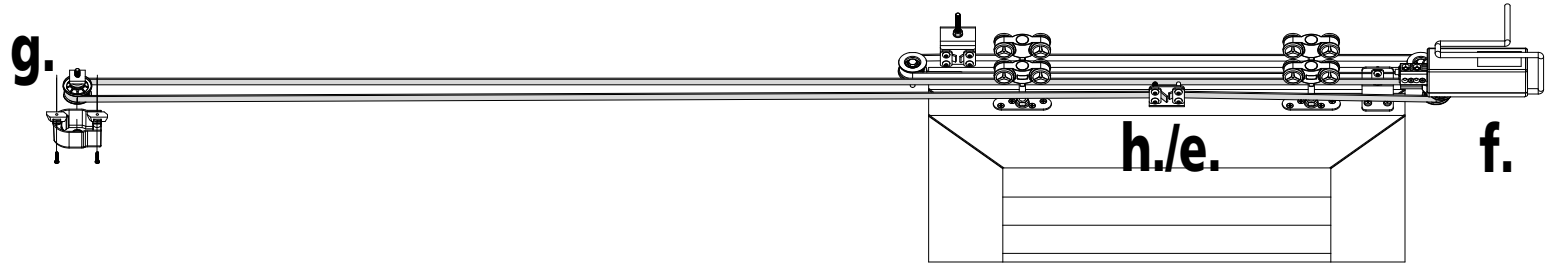
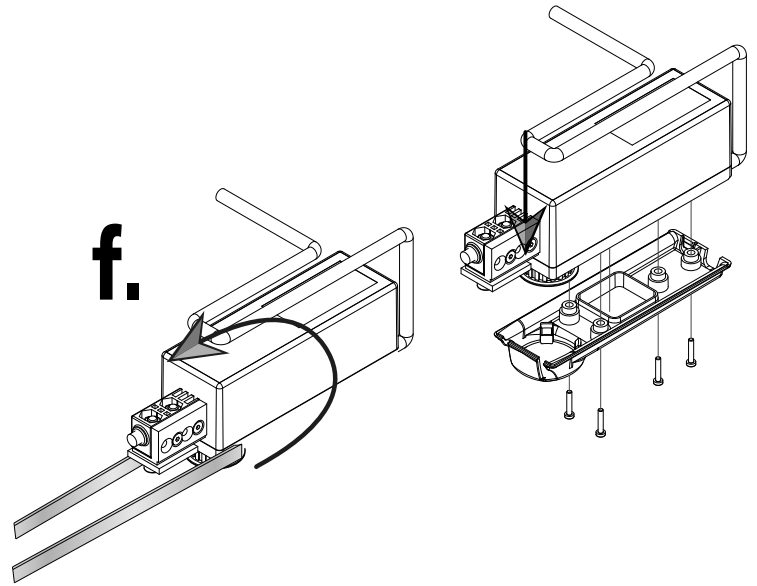
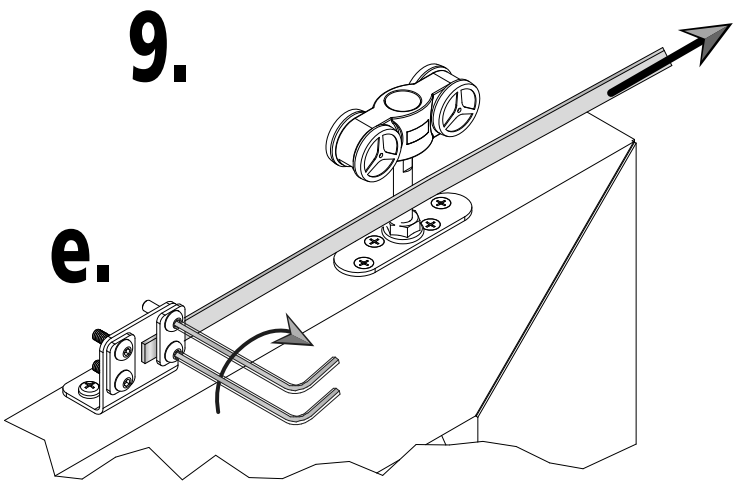

10.

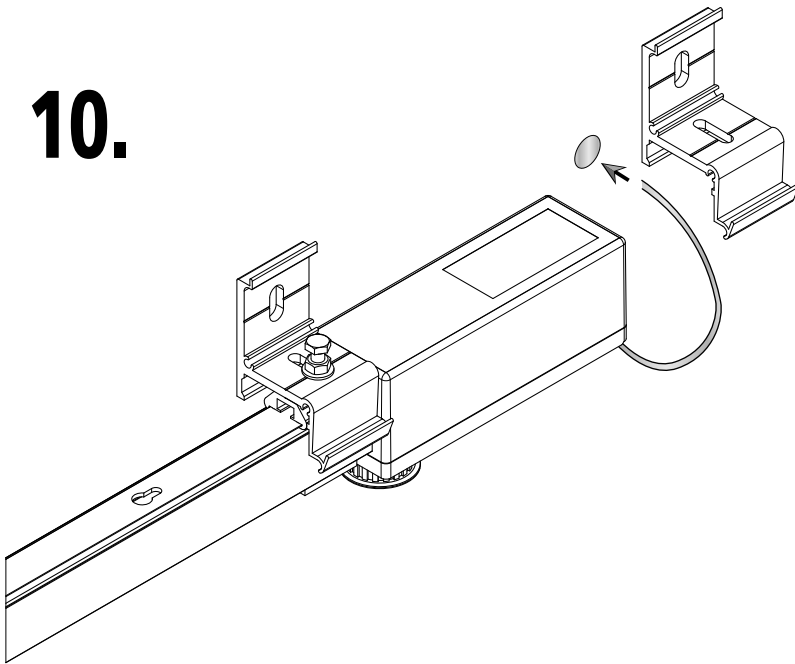

Se reporter au livret
de mise en service

Refer to the notebook of
installation instructions

Sich auf das Buch von
Inbetriebnahme beziehen

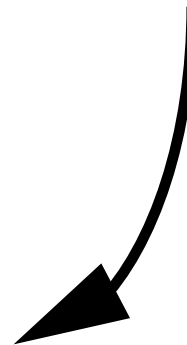
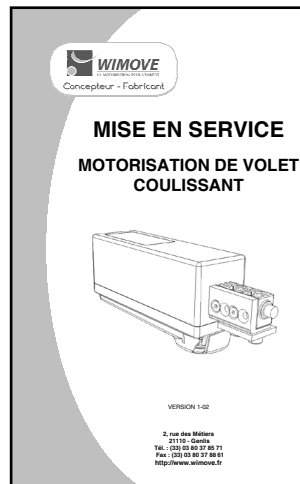

11.

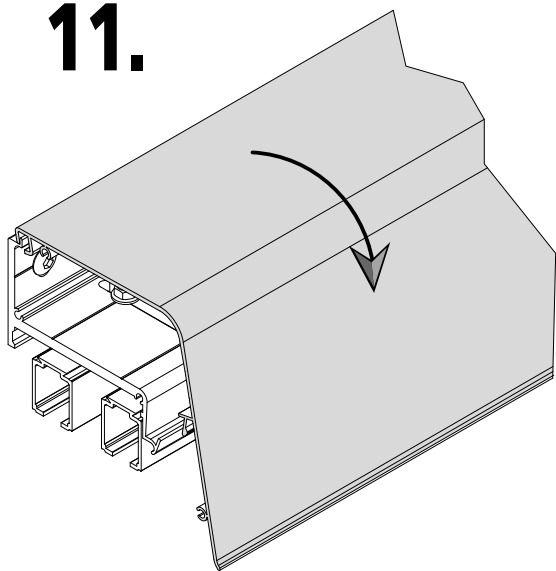

a.

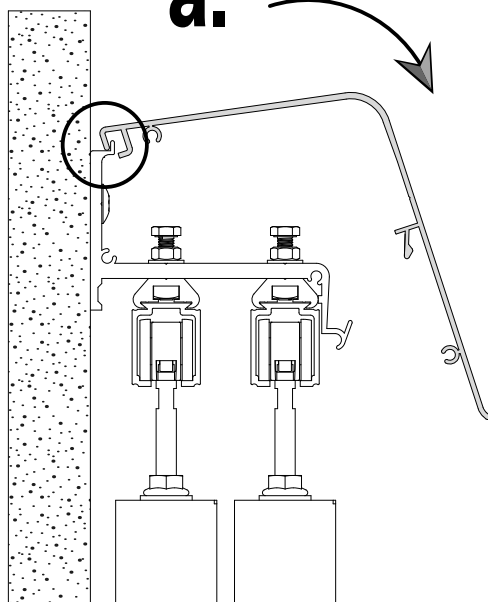

b.

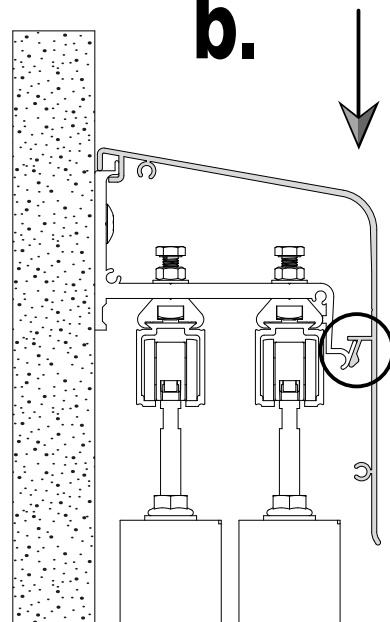

12.

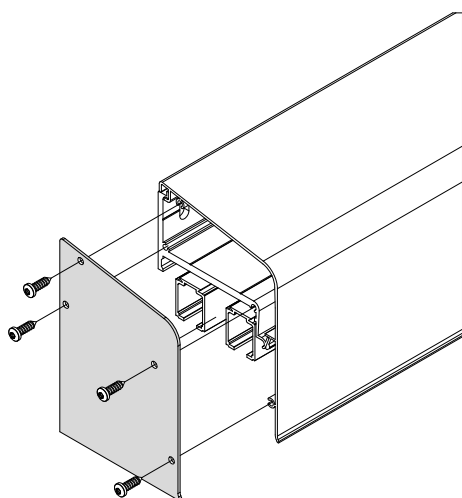

13.

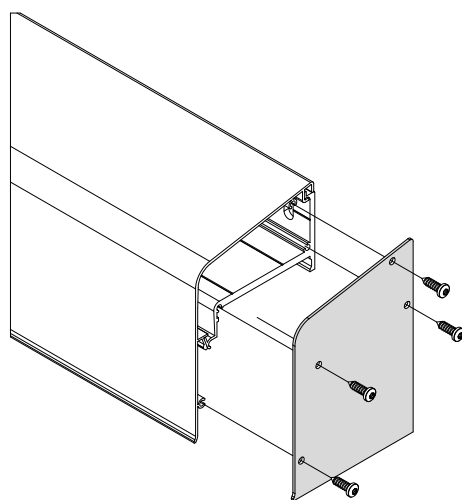

14.

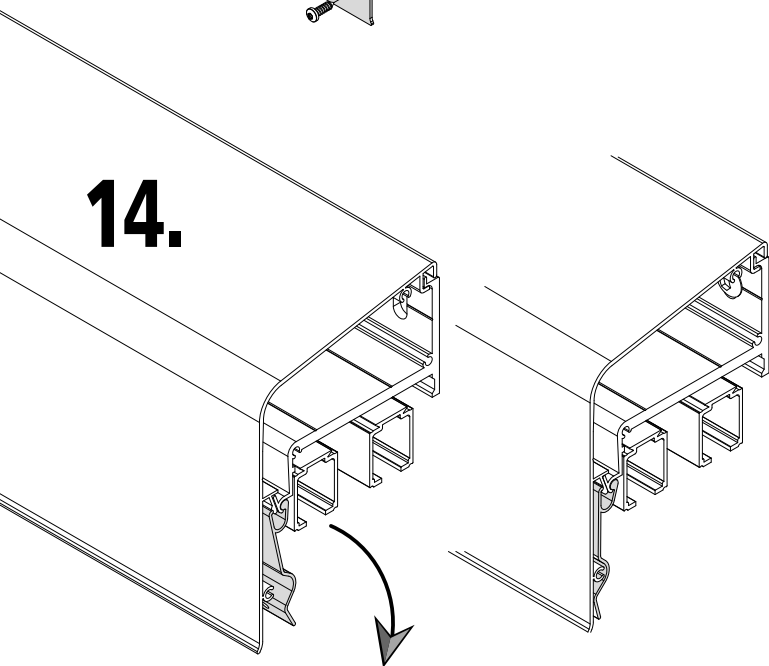

15.

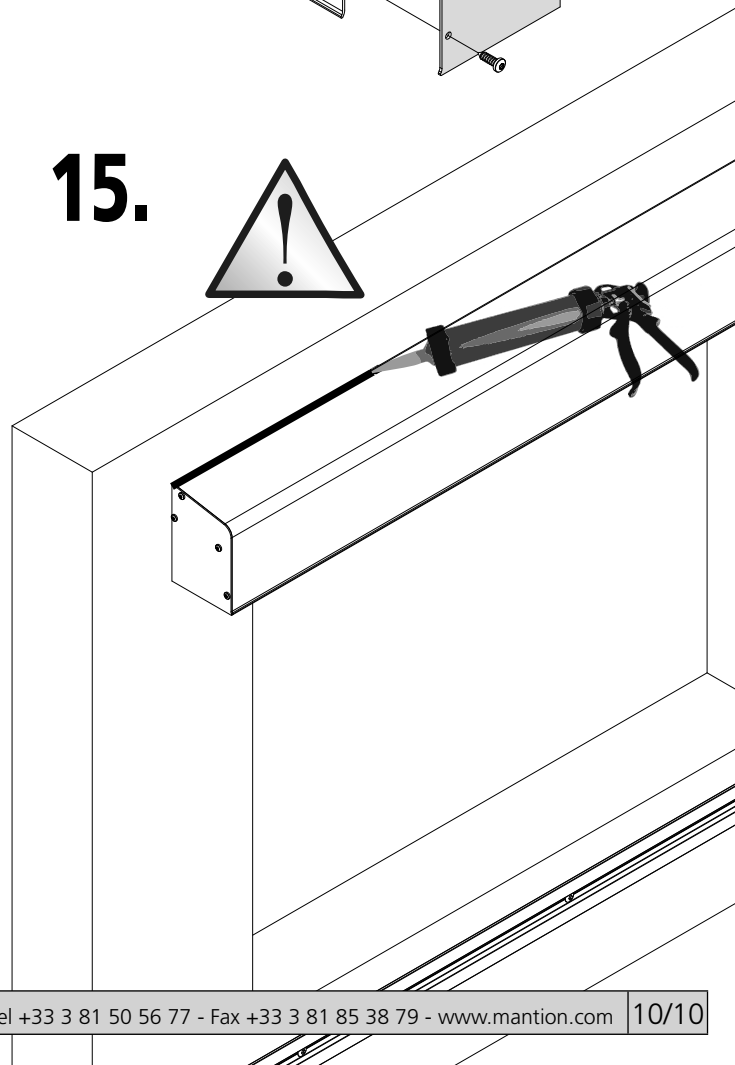

Clipser une pince tous les 1 m environ
 Aufclipsen jeder 1 m (cerca)
 Clip the clamps approximately every 1 m.
 Engatillar los clips cada metro mas o menos